

AIRCRAFT CONVERSION



NIJL Aircraft Docking
Punterweg 4
8042 PB Zwolle
The Netherlands

T +31 38 202 80 20
E info@nijlgroup.com

www.nijlgroup.com

CAGE code: H2BL2



NIJL[®]
aircraft docking

AIRCRAFT CONVERSION

FOR PASSENGER-TO-FREIGHTER (P2F) AND SPECIAL MODIFICATIONS

Key Benefits

- + Turn-key delivery of aircraft conversion access equipment
 - + Modular designs
 - + Docking system solutions
 - + Special access platform solutions
 - + Configurable to customer needs
 - + Optimized for task-oriented work flow and handling of tooling and aircraft components
 - + Following latest design standards and guidelines for commercial and military aircraft applications
 - + Experience with industry established aircraft conversion projects
- P2F: e.g. A320/A330/B737/B767/B777 series*
Special modifications: e.g. B737 series

Specifications

- 1 Single and multiple aircraft configurations
- 2 Ground mobile
- 3 Easy-to-manoeuvre
- 4 Safety / fall-protection features
 - Configurable railing solutions
 - Adjustable floor panel solutions
 - Height-adjustment solutions
- 5 Dedicated utility installation (electrical / pneumatics)
- 6 Intuitive user interfaces
- 7 Including safety labels, signs and instruction plates
- 8 Mixed aluminium-steel material selection for lightweightness, robustness and stability
- 9 Conservation to corrosion and aviation liquids

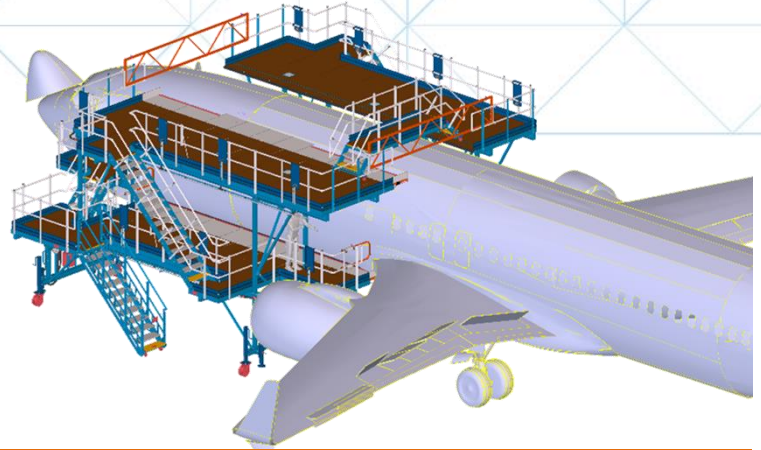

Passenger-to-Freighter (P2F) - Reference Project

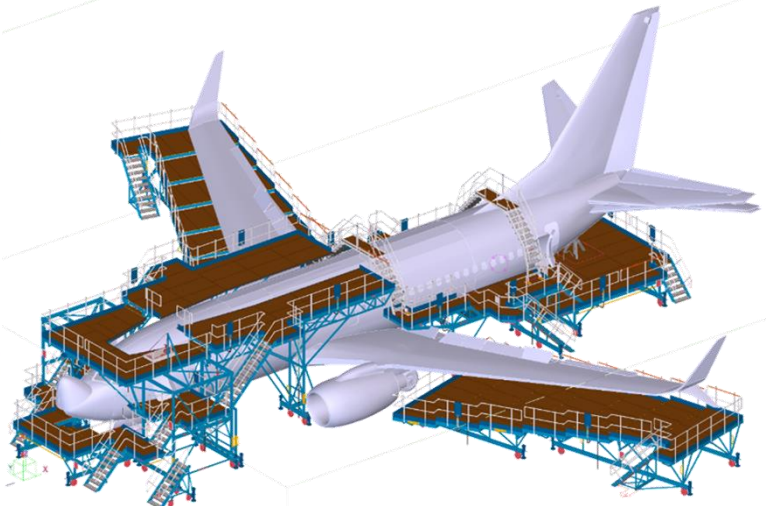

Special Mission Modifications - Reference Project



Dedicated Access Platform for P2F - Reference Project